

# ELEC 2507 Mock Final

Mia Cornell

April 8, 2026

**General Disclaimer:**

Users of this document should know this is for education purposes only and is not an alternative to an actual evaluation in ELEC 2507 - nor is it an exact representation of what the examination will look like. This document is for practice only and we are in no way claiming that this is what the evaluation will look like. If there are findings of any mistakes or general inquiries of the solutions please contact [president@desoc.ca](mailto:president@desoc.ca).

# 1 Questions

## 1.1 Question 1

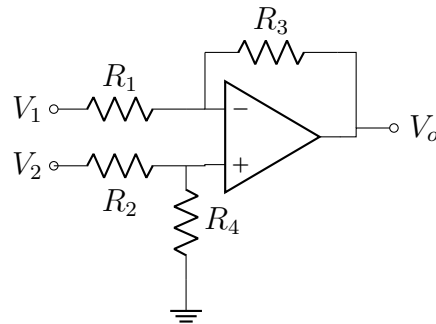

Figure 1: Question 1 Circuit

- Find the common mode gain.
- Find the differential mode gain.

## 1.2 Question 2

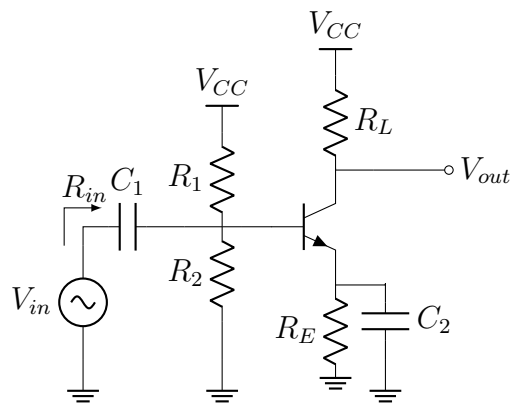

Figure 2: Question 2 Circuit

- Draw the small signal model for the circuit.
- Find the mid-band  $R_{in}$
- Find the mid-band gain.
- Find the mid-band  $R_{out}$

### 1.3 Question 3

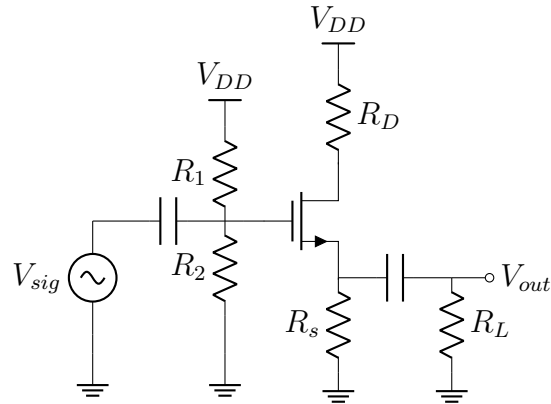

Figure 3: Question 3 Circuit

- Draw the small signal model for the circuit.
- Find the mid-band  $R_{in}$
- Find the mid-band gain.
- Find the mid-band  $R_{out}$

### 1.4 Question 4

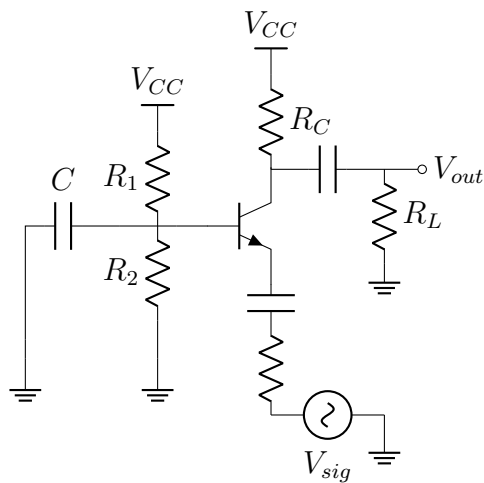

Figure 4: Question 4 Circuit

- Draw the small signal model for the circuit.
- Find the mid-band  $R_{in}$

- c) Find the mid-band gain.
- d) Find the mid-band  $R_{out}$

### 1.5 Question 5

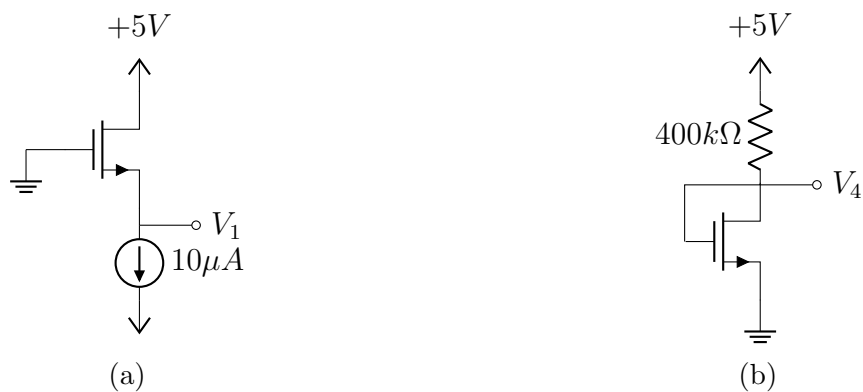

Figure 5: Question 5 Circuit

For each of the circuits, find the labeled node voltages. For all transistors,  $k'_n(W/L) = 0.5\text{mA/V}^2$ ,  $V_t = 0.8\text{V}$ , and  $\lambda = 0$ .

### 1.6 Question 6

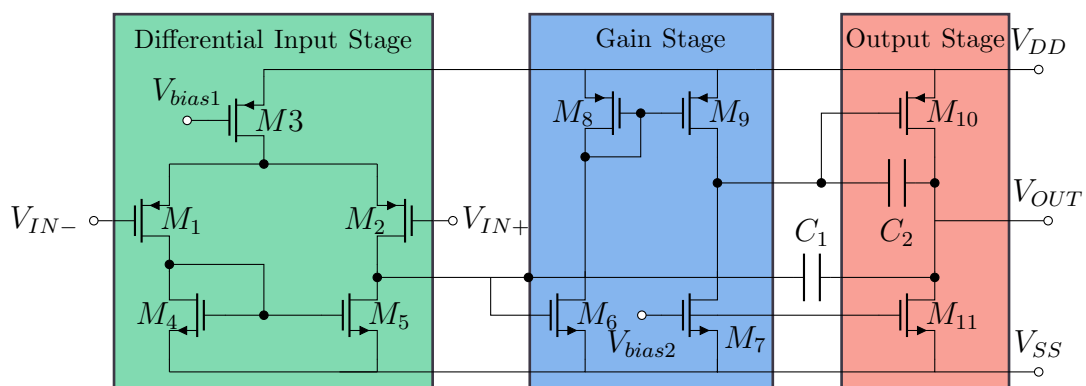

Figure 6: Question 6 Circuit

---

Qualitatively analyze the circuit.

Hint: Discuss the following:

- Input Stage
- Gain Stage
- Output Stage